

# Nest E3.1

1200 x 800



### Nestable euro-size plastic pallet for light loads

This lightweight plastic pallet offers an outstanding weight/load ratio. Empty pallets can be nested to achieve optimal volume reduction: 60 pallets per pile. Through bevelled edges on all four sides pallet piles can be unstacked easily by a fork-lift truck. The version with 3 runners can be used with conveyor technology.

#### Bottom support



> 9 feet (9F)



> 3 runners (3R)

#### Deck options



> open deck (OD)



Bevelled edges on all four sides



Nestable plastic pallets require less floor space.

## Technical data\*1

	Bottom support	Top deck	Dimensions [mm]	Load capacities*2 [kg]			Weight [kg]		Pallets per	
				Static	Dynamic	Racking	HDPE	PO	Stack	Truck
Nest E3.1 (OD-9F)	9 feet, nestable	open	1200 x 800 x 140	2700	900	—	6,0	6,5	60	1980
Nest E3.1 (OD-3R)	3 runners		1200 x 800 x 150	3600	1200	—	9,0	9,5	16	528

Entry: 4 ways | Nesting height: 37 mm | Safety rim: 5 mm (optional without)

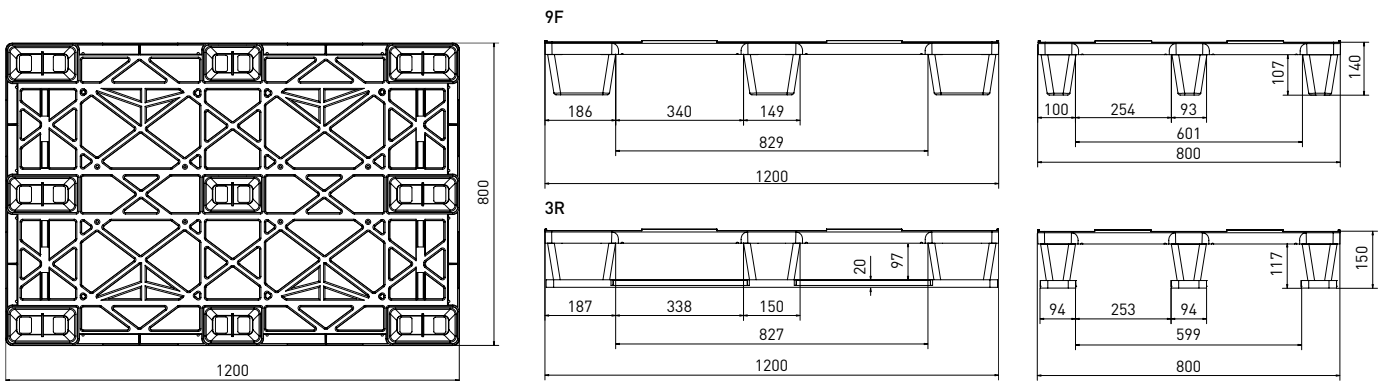

nominal sizes in mm

## Options

- Color:  [other colors on request\*3] > Individual marking\*3
- Anti-slip:  safety rim
- ESD prevention:  —



\*1 Figures can vary depending on the raw material used and options applied. \*2 Guideline values are based both on experience and parts of test ISO 8611, which tests with evenly distributed loads at room temperature (20°C). Varying data may result from different conditions of usage. Your specific requirements can be identified upon request. \*3 Minimum quantity required - PO pallets should only be used and stored in a dry environment. We reserve the right to change any of the stated information without prior notice.